



# *USER INSTRUCTIONS*

## *Kammer Multi-Z*

Severe Service Valves

FCD KMENIM1632-01 05/10

*Installation*  
*Operation*  
*Maintenance*

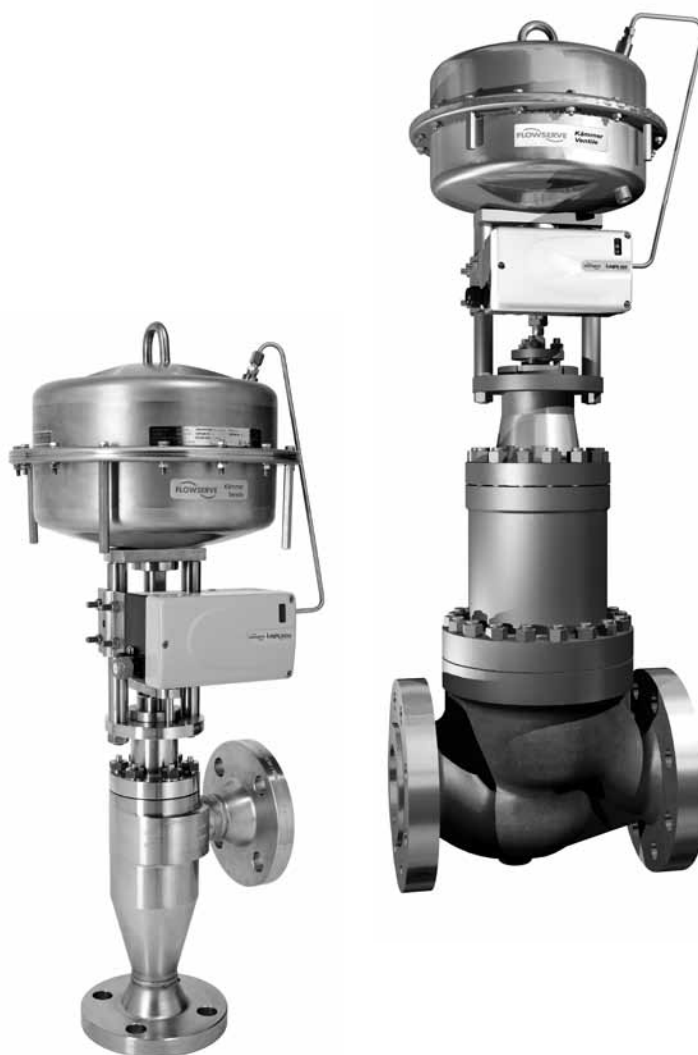

INDEX

- 1. **Using Flowserve valves and actuators correctly**
  - 1.1 General
  - 1.2 Terms concerning safety
  - 1.3 Protective clothing
  - 1.4 Qualified personal
  - 1.5 Installation
  - 1.6 Spare parts
  - 1.7 Service/repair
  - 1.8 Storage
  - 1.9 Valve and actuator variations
- 2. **Unpacking**
  - 2.1 Packing slip
  - 2.2 Lifting
  - 2.3 Transport damage
- 3. **Installation**
- 4. **Quick check**
- 5. **Maintenance**
- 6. **Remove and install actuator**
  - 6.1 **Remove actuator**
    - 6.1.1 Actuators with yoke rods
    - 6.1.2 Actuators with cast yoke and yoke counter nut
    - 6.1.3 Actuator with clamped cast yoke
  - 6.2 **Install actuator**
    - 6.2.1 Actuators with yoke rods
    - 6.2.2 Actuators with cast yoke and yoke counter nut
    - 6.2.3 Actuator with clamped cast yoke
- 7. **Disassemble and assemble valve**
  - 7.1 Valve part list
  - 7.2 Disassemble valve
  - 7.3 Assemble valve
- 8. **Troubleshooting chart**

1 **USING KÄMMER VALVES AND ACTUATORS CORRECTLY**

1.1 **General**

The following instructions are designed to assist in unpacking, installing and performing maintenance as required on Multi-Z valves. Product users and maintenance personnel should thoroughly review this bulletin prior to installing, operating or performing any maintenance. Refer to separate manuals to cover IOMs for actuators positioners and accessories.



**DANGER:** *In most cases valves and actuators are designed for specific applications (e.g. with regard to medium, pressure, temperature). For this reason they should not be used in other applications without first contacting the manufacturer.*

1.2 **Terms concerning safety**

The safety terms **DANGER, WARNING, CAUTION** and **NOTE** are used in these instructions to highlight particular dangers and/or to provide additional information on aspects that may not be readily apparent.



**DANGER:** *indicates that death, severe personal injury and/or substantial property damage **will** occur if proper precautions are not taken.*



**WARNING:** *indicates that death, severe personal injury and/or substantial property damage **can** occur if proper precautions are not taken.*



**CAUTION:** *indicates that minor personal injury and/or property damage can occur if proper precautions are not taken.*



**NOTE:** *indicates and provides additional technical information, which may not be very obvious even to qualified personnel. Compliance with other, not particularly emphasised notes, with regard to transport, assembly, operation and maintenance and with regard to technical documentation (e.g. in the operating instruction, product documentation or on the product itself) is essential, in order to avoid mistakes, which, in themselves, might directly or indirectly cause severe personal injury or property damage.*

1.3 **Protective clothing**

Kammer products are often used in problematic applications (e.g. extremely high pressures, dangerous, toxic or corrosive mediums). In particular valves with bellows seals point to such applications. When performing service, inspection or repair operations always ensure, that the valve and actuator are depressurised and that the valve has been cleaned and is free from harmful substances. In such cases pay particular attention to personal protection (protective clothing, gloves, glasses etc.).

1.4 **Qualified personnel**

Qualified personnel are people who, on account of their training, experience and instruction and their knowledge of relevant standards, specifications, accident prevention regulations and operating conditions, have been authorised by those responsible for the safety of the plant to perform the necessary work and who can recognise and avoid possible dangers.

## 1.5 Installation



**DANGER:** Before installation check the order-no, serial-no. and / or the tag-no. to ensure that the valve/actuator is correct for the intended application.

Do not insulate extensions that are provided for hot or cold services.

Pipelines must be correctly aligned to ensure that the valve is not fitted under tension.

## 1.6 Spare parts

Use only Kämmer original spare parts. Kämmer cannot accept responsibility for damages that occur from using spare parts or fastening materials from other manufactures. If Kämmer products (especially sealing materials) have been on store for longer periods check these for corrosion or deterioration before using these products. Fire protection for Kämmer products must be provided by the end user.

## 1.7 Service/repair

To avoid possible injury to personnel or damage to products, safety terms must be strictly adhered to. Modifying this product, substituting non-factory parts, or using maintenance procedures other than those outlined in this instruction could drastically affect performance and be hazardous to personnel and equipment, and may void existing warranties. Between actuator and valve there are moving parts. To avoid injury Between actuator and valve there are moving parts. To avoid injury do not work for maintenance purpose in this area while valve is in motion.

Apart from the operating instructions and the obligatory accident prevention directives valid in the country of use, all recognised regulations for safety and good engineering practices must be followed.

**WARNING:** Before products are returned to Kämmer for repair or service, Kämmer must be provided with a certificate which confirms that the product has been decontaminated and is clean. Kämmer will not accept deliveries if a certificate has not previously been provided (a form can be obtained from Kämmer).



## 1.8 Storage

In most cases Kämmer Products are manufactured from stainless steel. Products not manufactured from stainless steel are provided with an epoxy resin coating. This means that Kämmer products are well protected against corrosion. Nevertheless Kämmer products must be stored adequately in a clean, dry environment. Plastic caps are fitted to protect the flange faces and to prevent the ingress of foreign materials. These caps should not be removed until the valve is actually mounted into the system.

## 1.9 Valve and actuator variations

These instructions cannot claim to cover all details of all possible product variations, nor in particular can they provide information for every possible example of installation, operation or maintenance. This means that the instructions normally include only the directions to be followed by qualified personal where the product is being used for is defined purpose. If there are any uncertainties in this respect particularly in the event of missing product-related information, clarification must be obtained via the appropriate FLOWSERVE sales office.

## 2 UNPACKING

While unpacking the valve care must be taken to prevent damage to valve actuator and optionally mounted accessories or piping.

### 2.1 Packing slip

Each delivery includes a packing slip. When unpacking, check all delivered valves and accessories using this packing slip.

### 2.2 Lifting

Larger valves can be lifted using slings on the yoke rods or, if present, on the lugs provided for this purpose. If slings are used, attach them so that the outer tubing or attaching parts are not damaged.



**DANGER:** If slings are used, be aware that the centre of gravity of the valve may be above the lifting point. In this case, secure or support the valve against rotating to prevent damage or personnel injury.



**WARNING:** Lifting lugs on the actuators are designed only for removing the actuator from the valve. They are not for lifting or moving the whole actuator/valve assy. In this case the lugs could break and the valve could cause damage or injure personnel.

### 2.3 Transport damage

- Report transport damage to the carrier immediately.
- In case of discrepancies, contact your nearest FLOWSERVE sales office.

## 3 INSTALLATION

Usually Flowserve valves are supplied with top mounted actuator. In case of separately provided or owner used actuators, please refer to the appropriate manual to assemble the actuator to the valve.

3.1 Before installing the valve into the pipeline, inspect the valve body and the pipeline to ensure that they are not contaminated with foreign material such as welding chips, scale, oil grease or dirt.

3.2 Clean inside of valve body, pipeline and gasket contact surface.

3.3 Install the valve in an upright position (actuator on top), to ease maintenance.

3.4 Install the valve so that the flow through the valve conforms to the direction indicated by the flow arrow shown on the front of the body.

3.5 Make sure that sufficient overhead clearance above the actuator is maintained, to allow for disassembly of actuator from the valve body (refer to separate IOM for specific actuator model and type).

3.6 If the valve is to be welded into the pipeline, make sure that the valve is shielded from excessive heat.

3.7 Connect supply pressure and signal lines. Control valves are supplied with a positioner. The end connections for supply pressure and signal are clearly marked. Actuator and positioner are suitable for max. 6 bar (87 psi) supply pressure. If the supply pressure exceeds the pressure specified on the nameplate, a pressure reduction station is required. If instrument air is not available, install an oil separator / air filter in the air inlet line. All connections must be leak free

**4 QUICK CHECK**

Before operation, check the valve as follows:

- 4.1 Open and close the valve, and observe the movement of the actuator stem. The movement must be smooth and linear.
- 4.2 Check for maximum stroke through signal change.
- 4.3 Check all electrical wiring for tight connection.
- 4.4 Tighten gland nut or packing bridge nuts (acc. to design) Fig.: 1 and table: 1 or Fig.: 2 and table: 2

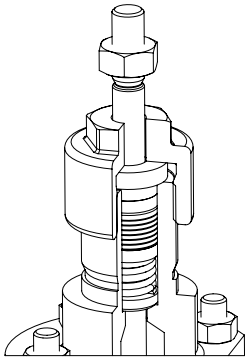

Thread	Torque (NM)	
	PTFE	Graphite
M30 x 1.5	7	17.5
M38 x 1.5	11.5	20.5
M45 x 1.5	27	48

Fig.: 1 and table: 1 - torque for gland nut

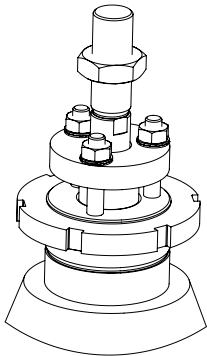

Thread	Torque for bolts acc. to DIN 939
M10	8 NM
M12	10 NM

Fig.: 2 and table: 2 - for packing bridge

- 4.5 Check fail-safe position. To do this, switch power off and observe whether the valve opens, closes or holds position as defined.
- 4.6 After use at fluctuating operating temperatures, re-tighten all fastener connections and check for leaks.

**5 MAINTENANCE**

Flowserve valves are designed for normal wear and have to be inspected and maintained at defined intervals.

- 5.1 Check valves for correct functioning at regular intervals (at least once every 6 months) as follows. This check can be made when installed and in many cases without interrupting production. If internal defects are suspected, see section "Disassembly and Assembly of Valve".
- 5.2 Examine gaskets for leaks and if necessary re-tighten fasteners.
- 5.3 Check bellows gasket and test connection – if present – for

external leaks.

- 5.4 Check valve for damage caused by corrosive residues or corrosive vapours.

- 5.5 Clean valves and repaint as necessary.



**WARNING:** To prevent a build-up of electrostatic charge clean the actuator/valve with a damp cloth only.

- 5.6 Check packing bridge or gland nut for correct torque (see tables 1 or 2).



**NOTE:** An excessively tightened gland nut can cause excessive packing wear and can hinder the free movement of the plug stem.

- 5.7 If possible, open and close valve and check for maximum stroke and smooth movement of the plug stem. Irregular movement of the plug stem may indicate internal defects.



**NOTE:** With graphite packing, irregular movement of the plug stem is normal.



**WARNING:** Keep hands, hair, clothing, etc. away from all moving parts. Failure to do so can lead to serious injury.

- 5.8 Check all accessories for firm seating.

- 5.9 Close supply pressure and check the fail-safe position.

- 5.10 Check stem boot, if present, for wear.

- 5.11 Check pneumatic actuator for leaks. To do this, spray housing, air connections and plug stem guide with leak spray and check for any bubble formation.

- 5.12 Clean plug stem.

- 5.13 Check external piping and fittings for leaks. Retight or replace fittings if necessary.



**NOTE:** For further information regarding service and maintenance please contact your nearest FLOWSERVE office.



**DANGER:** On actuators with aluminium cases the actuator springs must be renewed with original spare parts every 10

years or after 50.000 operating hours which ever occurs first.

## 6 REMOVE AND INSTALL ACTUATOR

**General Information.** We recommend separating the actuator from the valve during all repair work. However, many maintenance and adjusting operations can be performed in an installed condition.



**WARNING:** Large actuators may require lifting equipment. If slings are used, be aware that the centre of gravity of the valve may be above the lifting point. In this case, secure or support the valve against rotating, to prevent damage or injury to personnel.

### 6.1 Remove actuator



Switch off electricity, if an electric actuator is installed, disconnect air supply if a pneumatic actuator is installed. If present disconnect positioner from stem attachment .



**DANGER:** Depressurise the supply line to atmospheric pressure and drain all fluids from the valve before working on the actuator. Failure to observe this instruction can lead to serious injury.

**DANGER:** Make sure that the actuator is pressure-free before performing maintenance work. Failure to observe this instruction can lead to serious injury.

#### 6.1.1 Actuators with yoke rods

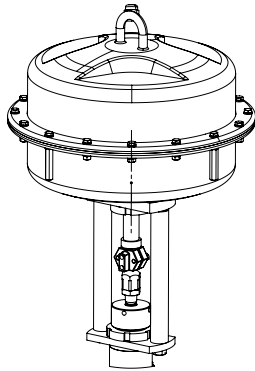

Fig.: 3 Yoke rod design

- 6.1.1.1 As required remove any external wiring and piping.
- 6.1.1.2 On vertical separated coupling loose coupling screws and remove the two vertical separated coupling parts.
- 6.1.1.3 On horizontal separated coupling loose coupling screws and nuts. Coupling parts stays on the valve stem and the actuator stem.

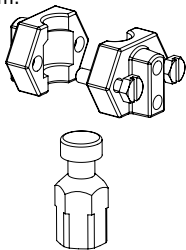
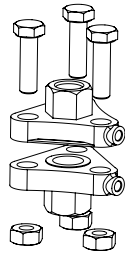

Fig.: 4 Vertical separated coupling



5 Horizontal separated coupling

- 6.1.1.4 Remove yoke rod retaining nuts and carefully lift the actuator assembly from the valve.
- 6.1.1.5 If necessary remove the lower coupling half from the stem after loosening the locknut.
- 6.1.1.6 As required, remove the yoke plate, gland nut / packing bridge assembly - . Remove yoke, locknut and remove the yoke plate.



**NOTE:** Ensure that the plug assembly is not rotated with the plug seated. This may cause irreparable damage to the seating faces.

#### 6.1.2 Actuators with cast yoke and yoke locknut

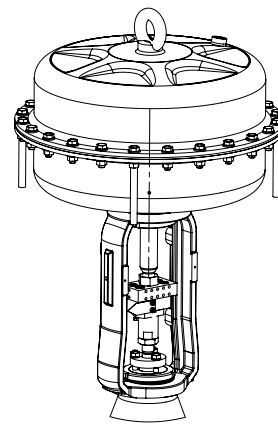

Fig.: 6 Cast yoke with locknut design

- 6.1.2.1 As required remove any external wiring and piping.
- 6.1.2.2 Loosen coupling screws and nuts. Coupling parts remain on the valve stem and the actuator stem.

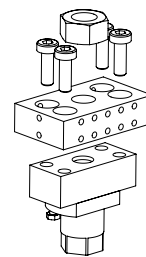

Fig.: 7 Horizontal separated coupling

- 6.1.2.3 If the outside diameter of the packing bridge is larger than the inside diameter of the locknut, remove the packing follower bolting and packing bridge.
- 6.1.2.4 Remove yoke retaining nut and carefully lift actuator assembly from the valve



**NOTE:** Ensure that the plug assembly is not rotated with the plug seated. This may cause irreparable damage to the seating faces.

**6.1.3 Actuators with clamped cast yoke**

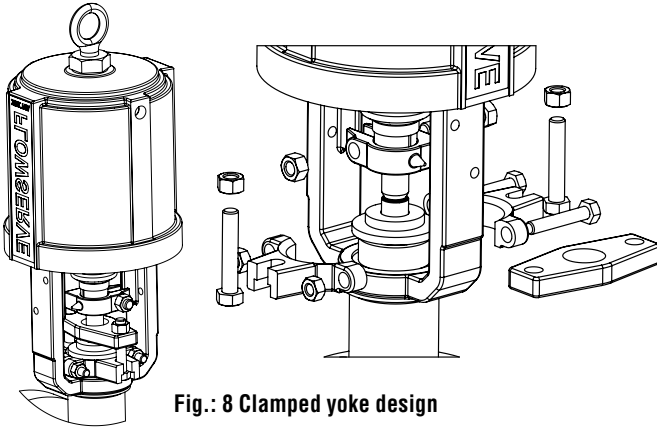

**Fig.: 8 Clamped yoke design**

- 6.1.3.1 As required remove any external wiring and piping.
- 6.1.3.2 Loosen coupling fastener.
- 6.1.3.3 Remove packing bridge fastener.
- 6.1.3.4 Remove clamp fastener and carefully thread the actuator assembly from the valve by rotating the actuator.

! **NOTE:** Ensure that the plug assembly is not rotated with the plug seated. This may cause irreparable damage to the seating faces.

**6.2 Install actuator**

**6.2.1 Actuators with yoke rods**

- 6.2.1.1 The actuator stem must be fully extended: Actuators with air-to-open action must be fully vented. Actuators with air-to-close action apply supply pressure
- 6.2.1.2 Manually depress the plug stem to ensure the plug is fully seated
- 6.2.1.3 Screw coupling locknut and lower coupling half as far as possible onto plug stem.
- 6.2.1.4 If not present place the yoke rod onto the bonnet and fix with the locknut and ensuring that the actuator faces in the correct direction.
- 6.2.1.5 Place the actuator assembly on the valve engaging the yoke rod threads in the bonnet.

! **NOTE:** Ensure that the plug assembly is not rotated with the plug seated. This may cause irreparable damage to the seating faces.

- 6.2.1.6 On vertical coupling refit the 2 the coupling halves, ensuring that the arrows, embossed on the coupling halves, point upward towards the actuator, and secure with 2 retaining screws.

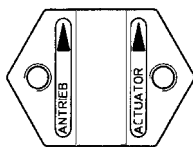

**Fig.: 9 Coupling half with installation arrows**

- 6.2.1.7 On horizontal separated coupling also align the bolt circle of the both couplings and replace fasteners.
- 6.2.1.8 Respectively apply or release supply pressure air to actuator to half stroke and refit and tighten yoke nuts fully.
- 6.2.1.9 As required reconnect all tubing and wiring.

**6.2.2 Actuators with cast yoke and yoke locknut**

- 6.2.2.1 The actuator stem must be fully extended: Actuators with air-to-open action must be fully vented. Actuators with air-to-close action apply supply pressure
- 6.2.2.2 Manually depress the plug stem to ensure the plug is fully seated
- 6.2.2.3 Screw coupling locknut and lower coupling half as far as possible onto plug stem.
- 6.2.2.4 Place the actuator assembly and the yoke counter nut on the valve launching the yoke rod centre boring on the bonnet. Do not screw down the counter nut onto the yoke yet.

! **NOTE:** Ensure that the plug assembly is not rotated with the plug seated. This may cause irreparable damage to the seating faces.

- 6.2.2.5 If packing bridge is not already adapted, mount it to the bonnet before reuniting the coupling halves.
- 6.2.2.6 Unscrew the lower coupling part until it touches the upper coupling part. Continue screwing until the yoke is raising from the bonnet for about 2mm. Align the bolt circle of the both couplings.
- 6.2.2.7 Place and screw the coupling bolting.
- 6.2.2.8 Respectively apply or release supply pressure air to actuator to half stroke and refit and tighten yoke counter nut fully.

**6.2.3 Actuators with clamped cast yoke**

- 6.2.3.1 The actuator stem must be fully extended: Actuators with air-to-open action must be fully vented. Actuators with air-to-close action apply supply pressure
- 6.2.3.2 Manually depress the plug stem to ensure the plug is fully seated
- 6.2.3.3 Place the actuator assembly and packing bridge on the valve guiding the actuator stem thread onto the valve stem
- 6.2.3.4 Rotate the actuator assembly to screw it onto the plug stem until the yoke raises around 2 mm from the bonnet face.

! **NOTE:** Ensure that the plug assembly is not rotated with the plug seated. This may cause irreparable damage to the seating faces.

- 6.2.3.5 Apply supply air to the air-to-open version. Open the valve – by adding or releasing air from the actuator – until the yoke contacts the bonnet.
- 6.2.3.6 Replace both clamps – ensuring that the clamp chamfer faces in the direction of the actuator and tighten the clamp fasteners.
- 6.2.3.7 Place and tight the packing bridge fasteners.
- 6.2.3.8 Place and tighten the anti-rotation fasteners.

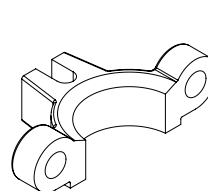

**Fig.: 10 Yoke clamp**

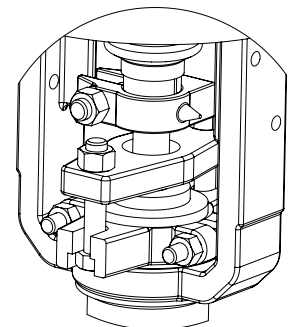

**Fig.: 11 Ready mounted cast clamped yoke**



**7 DISASSEMBLE AND ASSEMBLE VALVE**

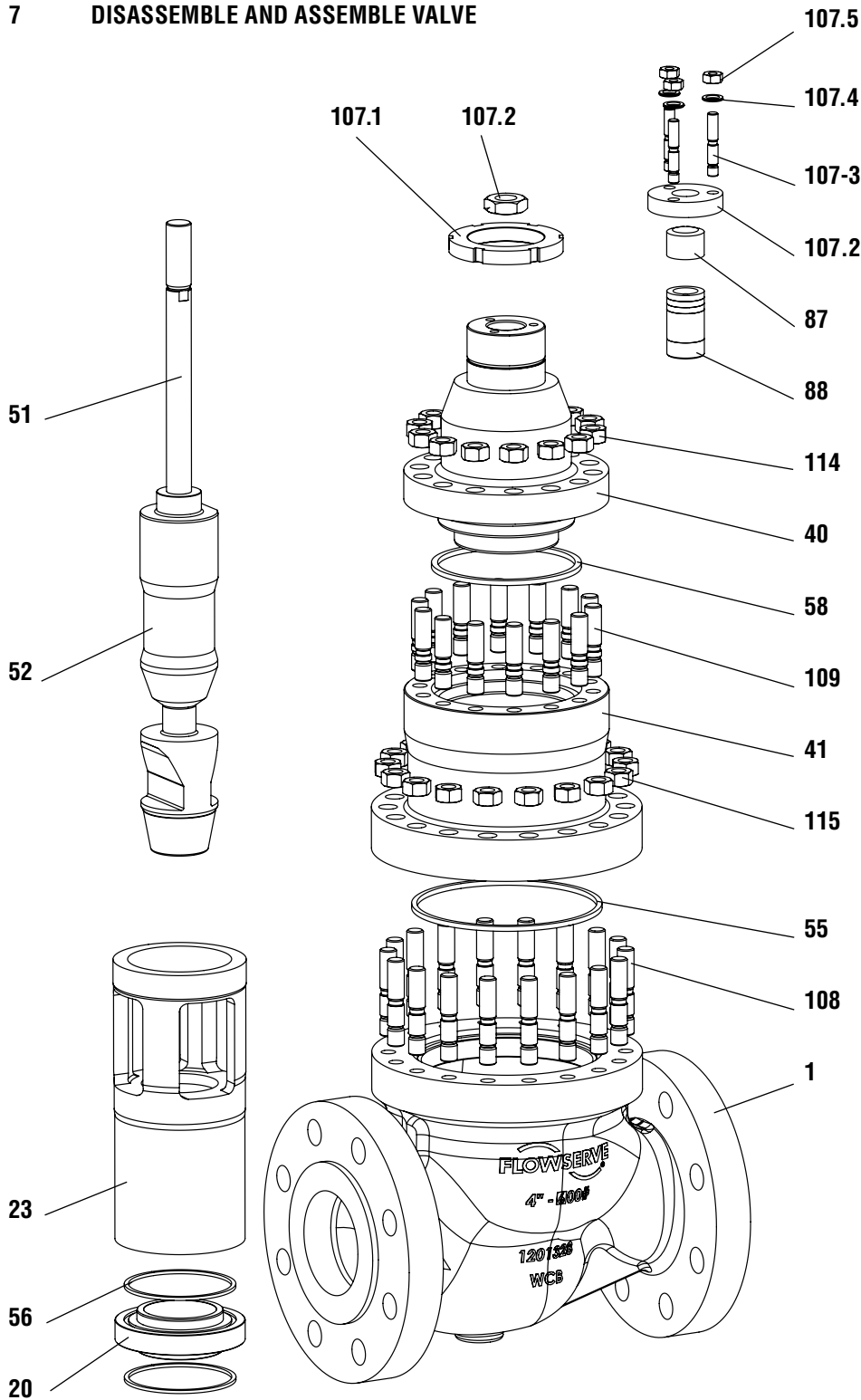

**7.1 Valve part list**

- 1 Body
- 20 Seat ring
- 23 Liner
- 40 Bonnet
- 41 Extension
- 51 Stem
- 52 Plug
- 55 Body gasket \*
- 56 Seat ring gasket \*
- 57 Bonnet gasket \*
- 65 Pressure balance seal \*
- 66 Pressure balance slide ring \*
- 87 Packing follower
- 88 Packing kit \*
- 107 Upper bolting kit
  - 107.1 Yoke counter nut
  - 107.2 Packing bridge
  - 107.3 Stud bolts
  - 107.4 Washer
  - 107.5 Hexagon nut
  - 107.6 Gland nut
  - 107.7 Stem counter nut
- 108 Body flange bolting studs
- 109 Bonnet flange bolting studs
- 114 Bonnet flange nut
- 115 Body flange nut

\* Recommended spare parts

**Fig.: 12 Standard globe cast body Multi-Z**

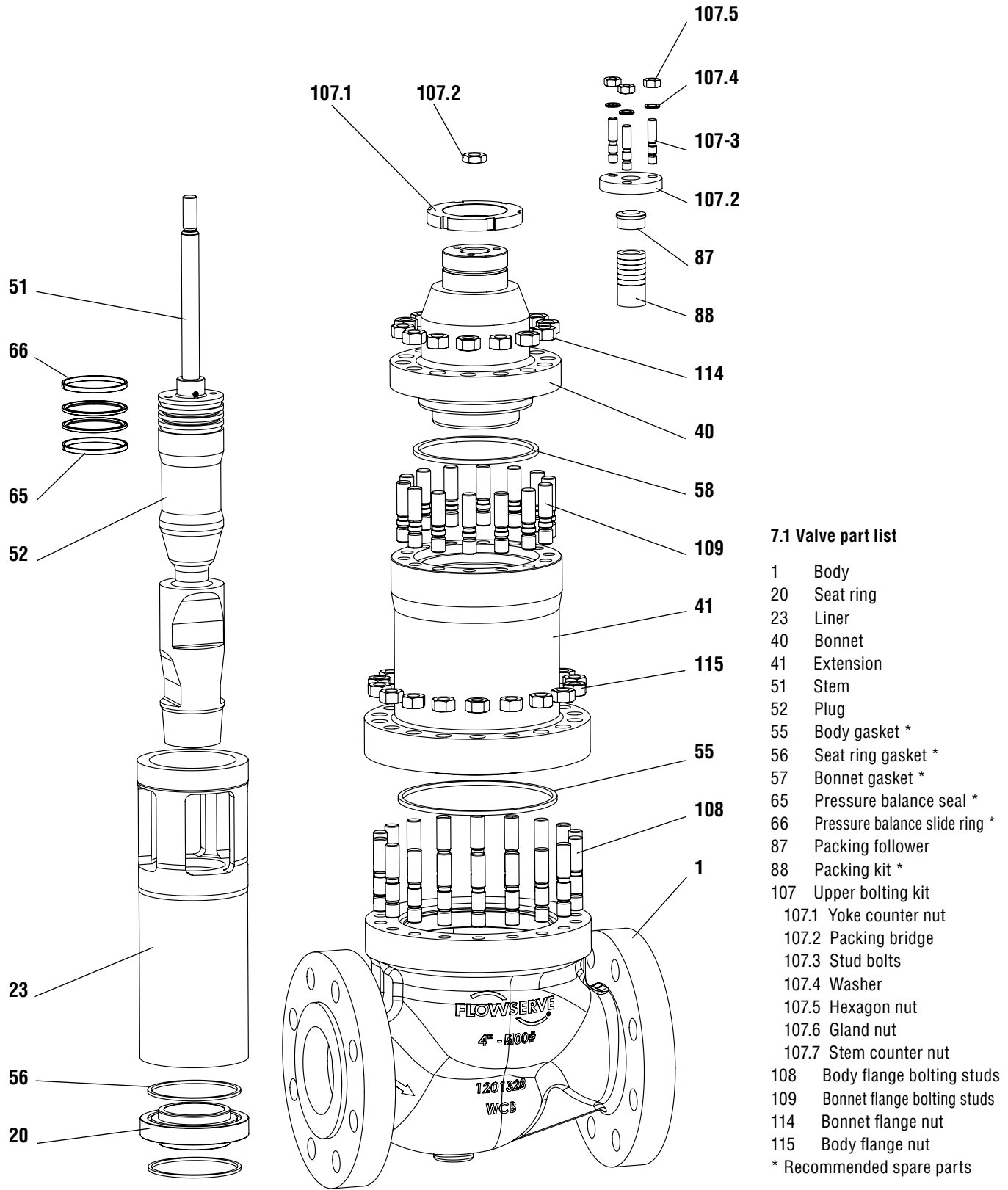

**7.1 Valve part list**

- 1 Body
  - 20 Seat ring
  - 23 Liner
  - 40 Bonnet
  - 41 Extension
  - 51 Stem
  - 52 Plug
  - 55 Body gasket \*
  - 56 Seat ring gasket \*
  - 57 Bonnet gasket \*
  - 65 Pressure balance seal \*
  - 66 Pressure balance slide ring \*
  - 87 Packing follower
  - 88 Packing kit \*
  - 107 Upper bolting kit
    - 107.1 Yoke counter nut
    - 107.2 Packing bridge
    - 107.3 Stud bolts
    - 107.4 Washer
    - 107.5 Hexagon nut
    - 107.6 Gland nut
    - 107.7 Stem counter nut
  - 108 Body flange bolting studs
  - 109 Bonnet flange bolting studs
  - 114 Bonnet flange nut
  - 115 Body flange nut
- \* Recommended spare parts

**Fig.: 13 Pressure balanced globe cast body Multi-Z**



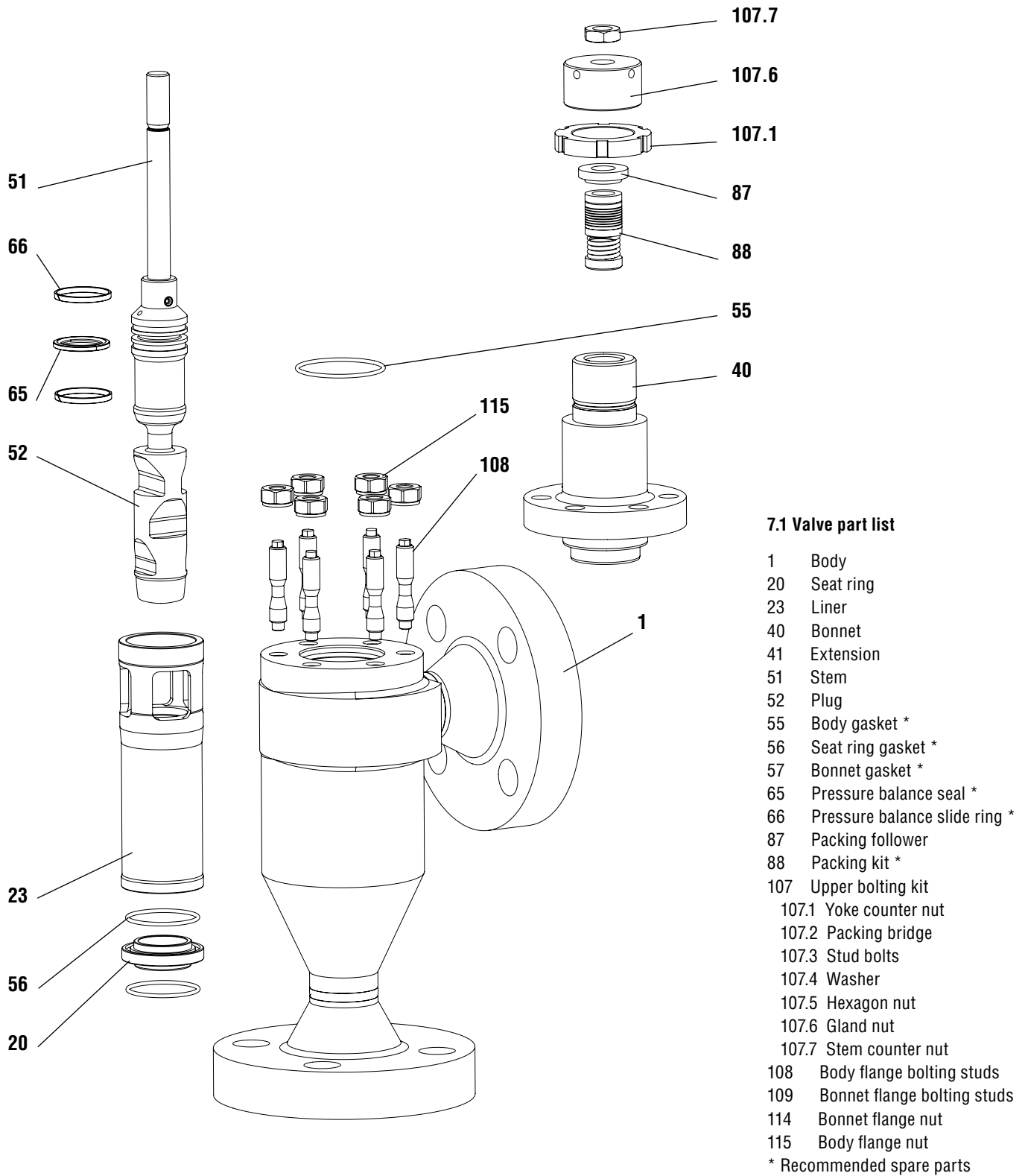

Fig.: 14 Pressure balanced angle body Multi-Z

## 7.2 Disassemble Valve

- 7.2.1 Unscrew and remove packing bridge (107.2) with bolting (107.3-107.5) – respectively the gland nut (107.6) .
- 7.2.2 On globe valves unscrew and remove nuts (114) from bonnet (40) stud bolts (109). Stud bolts (109) can remain in the bonnet (40).
- 7.2.3 On angle valves unscrew and remove nuts (115) from body stud bolts (108). Stud bolts (108) can remain in the body (1).
- 7.2.4 Carefully remove bonnet (40) from body (1) or extension (41). Use lifting lugs for heavy parts (Threads for lifting lugs are provided). Avoid canting while removing.
- 7.2.5 Carefully remove stem / plug (51+52 as one part). Use lifting lugs for heavy parts. Lifting lug can be screw onto the stem thread. Stem thread depends on pressure rate and actuator size. Refer to the ordering documents. Avoid canting while removing. Store safely to avoid damage.
- 7.2.6 Carefully remove Liner (23) with suitable tool. Use lifting lugs for heavy parts (Lifting lug threads are provided). Avoid to cant while dismounting. Store it safely to avoid damages.
- 7.2.7 On globe valves unscrew and remove nuts (115) from body stud bolts (108). Stud bolts (108) could stay in the body.
- 7.2.8 Remove seat ring (20) with a suitable tool. Use lifting lugs for heavy parts. (Threads for lifting lugs are provided). Store safely to avoid damage.
- 7.2.9 Check sealing and guiding faces of seat (20), plug (52), stem (51), Liner (23) and body (1) for damage. Gasket surfaces must be clean and free from damage.
- 7.2.10 Remove packing follower (87) from the bonnet (40) and press out the packing kit (88) from below, using a drift (the drift must have a slightly larger diameter than the plug stem).



**CAUTION:** To prevent damage to the plug, seat or plug stem, follow the above instruction precisely

- 7.2.11 Remove gaskets from body (1) and seat ring (20). Check grooves and guiding faces for damage. Surfaces must be clean and free from damage. Check sealing faces of seat for damage. Surfaces must be clean and free from damage.

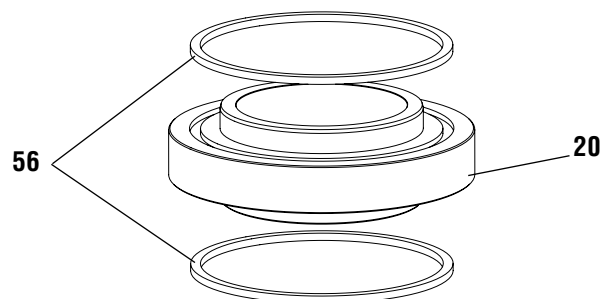

**Fig.: 15 Seat ring gasket configuration**

- 7.2.12 If plug is pressure balanced, remove guiding rings (66) and seal rings (65) from the plug (52). Depending on the sealing class there may be 1 or 2 pressure sealing units. Check grooves and guiding faces for damage. Surfaces must be clean and free from damage.

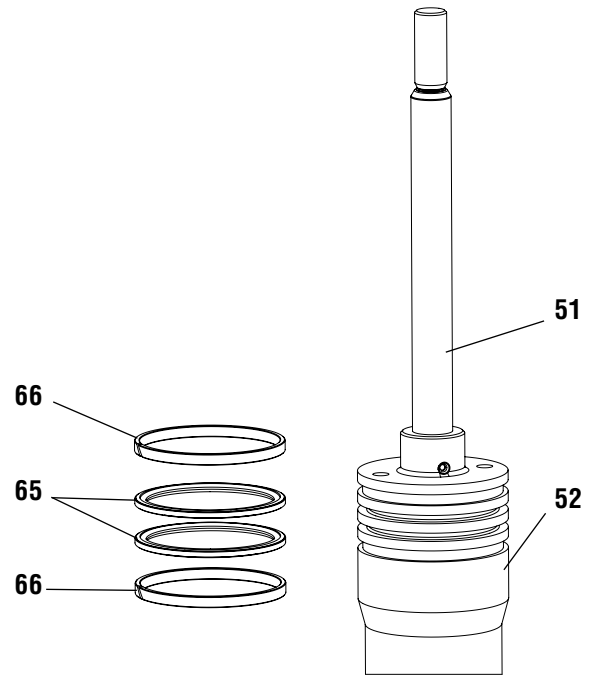

**Fig.: 16 Pressure balanced seal configuration**

- 7.2.13 Check plug guiding in the bonnet (40) for damage. Surfaces must be clean and free from damage.
- 7.2.14 Check packing area in the bonnet (40) for damage. Surfaces must be clean and free from damage.
- 7.2.15 If a seat ring (20) surface needs re-machining, seat and plug seating surfaces must be reworked. The seat angle on the metallic plug is 30°, on the seat ring 25°. On a soft seat ring the seat angle is 30°. If the valve is correctly assembled, lapping is not required.

**NOTE:** When re-machining the plug, protect plug stem from damage. The seat surface must be concentric to the plug stem. When re-machining the seat, the seat surface must be concentric to the seat outer diameter.

## 7.3 Assemble Valve

- 7.3.1 All worn or damaged parts must be replaced. Re-usable parts must be clean. Expendable parts such as gaskets, packing must always be replaced. (See valve part list for recommended spare parts)
- 7.3.2 Thoroughly clean the body (1), extension (41) and bonnet (40). No dirt or dust should be present on the valve parts.
- 7.3.3 Insert seat ring (20) with suitable tool. Place both gaskets (56) in its designated grooves. Use permitted grease for installation. Avoid canting while inserting.
- 7.3.4 If not in place install the body bolting studs (108) to it's designated places.
- 7.3.5 Place body gasket (55) in it's designated groove.
- 7.3.6 On globe valves place the extension (41) onto the body (40) mount and tight the body bolting nuts (115) crosswise.
- 7.3.7 Insert Liner (23) with suitable tool. All sealing faces have

to be free from dirt and damage. Use lifting lugs for heavy parts (Threads for lifting lugs are provided). Avoid canting while mounting.

7.3.8 On globe valves place bonnet gasket (58) in it's designated groove.



**NOTE:** One of the 4 windows of the Liner should face the exit line.

7.3.9 If a pressure balance (TG Ring) is present, place the sealing gaskets (65) on the piston of the plug (52).

- Place the back up O-Ring into the sealing grooves
- Heat-up the gaskets (in boiling water) for about 15 min. for easier assembling.
- Place the gaskets into grooves with suitable tool. (Can be ordered from Flowserve Essen GmbH).
- Calibrate the gasket with suitable tool. (Can be ordered from Flowserve Essen GmbH).

7.3.10 Place the upper guiding ring (66) into it's groove and carefully place the bonnet (40) over the piston. Place the lower guiding (66) ring into place when the bonnet (40) covers both sealing rings (65). Now let the bonnet (40) slide down until it stops.



**NOTE:** Move the bonnet over the plug stem and the plug piston very carefully to prevent damage.

7.3.11 On pressure balanced valves carefully guide bonnet/plug assy. through the liner (23) until the plug contacts the seat ring (20), ensuring not to damage the plug facing.

7.3.12 If no pressure balance is present carefully guide the plug (52) through the liner (23) until the plug contacts the seat ring (20), ensuring not to damage the plug facing.

7.3.13 On no pressure balance issue carefully move the bonnet (40) over the stem (51) into place, ensuring not to damage the stem facing.

7.3.14 On globe valves, if not already present place the bonnet bolting (109) to the extension (41)

7.3.15 Using a torque wrench, gradually tighten all nuts to the prescribed torques (see table 3) alternating crosswise.

7.3.16 Replace packing kit (88) in the order shown in the spare parts list by inserting packing rings one at a time tapping each one down with a suitable bushing.



**NOTE:** Ensure that the gaps in the packing rings are distributed evenly around the circumference in the packing box (gaps not in line). Different packings and fitting sequences are shown in the spare parts list.

7.3.17 Replace packing follower (87), packing bridge (107.2), nuts (107.5) and washers (107.4) – or gland nut (107.6) - and tighten all fastener to the prescribed torques (see table 2).

7.3.18 Place actuator on the valve, connect the coupling and adjust the valve (see 6.2)

7.3.19 Refit the piping unit (piping, positioner, fittings etc.) back in place. Tighten all fittings.

Thread	Stud bolts acc. to DIN 939				
	A193 GR. B7	A193 GR. B8	CK35	A2-70	1.7709
M8	20	20	-	20	-
M10	40	40	20	35	40
M12	65	65	35	60	65
M16	155	155	80	145	155
M24	520	520	265	270	520

Table 3: stud bolt torque (Nm) for body and bonnet fasteners

## 8 TROUBLESHOOTING PLAN

Problem	Possible cause	Remedy
Stem motion impeded	1. Packing too tight	1. Tighten union nut to somewhat more than "finger tight"
Excessive leakage	1. Bonnet/extension is loose 2. Worn or damaged seat ring/plug 3. Gaskets damaged 4. Inadequate actuator thrust 5. Plug incorrectly adjusted 6. Incorrect direction of flow	1. See step 7.3.15 for re-tightening the bonnet/extension correctly 2. Rework or replace seat ring/plug 3. Renew gaskets 4. Check air feed. If air feed is OK, contact dealer 5. Correctly adjust plug according to section 6.2 6. Check specification. Contact dealer
Inadequate flow	1. Plug incorrectly adjusted (short stroke) 2. Positioner defective 3. Operating requirements too high	1. Correctly adjust plug according to section 6.2 2. See operating instructions for positioner 3. Check operating data. Contact dealer
Blow out pipe leaks	1. Seat seal broken 2. Body seal broken	1. Replace seal 2. Replace seal



**Flowserve Essen GmbH**

Schederhofstrasse 71  
45145 Essen  
Germany  
Phone: +49 (0)201 8919 5  
Fax: +49 (0)201 8919 662

**Flowserve FCD**

Kämmer Valves  
1300 Parkway View Drive  
Pittsburgh, PA 15205  
USA  
Tel.: +1 412 787 8803  
Fax: +1 412 787 1944

Your contact:



All data subject to change without notice

©04.2010 Flowserve Corporation. Flowserve and Kämmer are registered trademarks of Flowserve Corporation